

ControlMate-FM

Fully modulating PRV Controller



The ControlMate range enables the outlet pressure of a Pressure Reducing Valve (PRV) to be controlled reliably and safely.

ControlMate-FM allows the pressure into a zone to be continually adjusted to any desired value, which is intelligently calculated by the controller according to the zone's actual demand (flow modulation) or according to a pre-programmed time of day.

- Maximum potential water savings
- Improved level of service to consumers
- Continuously variable outlet pressure profiling
- Eliminates pressure "shocks" to system – reducing burst frequency
- Outlet pressure can be set remotely – no need to visit site
- Optimise profile according to demand or time (eg summer/winter)
- In-built pulse unit failure (zero flow) detection and automatic response
- Modular construction for ease of access to controls
- Fully compatible with Hydraulic Actuator
- No external power supply requirements. Powered by an internal battery with an expected operational life of over five years

ControlMate-FM

Technical Specification

Display type

2 line x 16 character backlit super-twist, fully potted

Communication & programming

Local interface: Sealed local display, with 2 push-button switches

Infra-red communication: Ultra-high speed 20kbaud link via I/R probe to standard RS232 port on PC

Telemetry: Connector for multi-communication options: BABT-approved internal modem or multi-communication link for PAKNET, GSM, radio, etc.

Pressure channel

Sensor type: Inbuilt transducers: 0-10bar, 0-16bar, 0-25bar.

External transducer optional.

Accuracy: Typically 0.2% of full-scale range

Pressure connection: Quick-fit nickel-plated brass connector and push-fit 6mm connector

Flow channel

Sensor type (pulse input): Solid state MeterMate, LRP, HRP, PSM or any other form of volt-free pulsed signal

Input frequency: 0-100Hz pulse input requiring minimum mark 4.9mS, minimum space 4.9mS

Connector: 10-pin military specification, to IP68

Data storage

Channels: 2 pressure + 1 flow (additional flow optional)

Memory capacity: 120kbytes scrolling memory with storage for 60,000 values

Logging interval: 10s, 30s, 1min, 5min, 15min, 60min

Sampling interval:

As above but independent of logging interval

Power source

Battery type: Fully-sealed internal lithium batteries with expected operating life of 5 years or more

Operating environment

Temperature: -10°C to +50°C, must avoid freezing of water connections

Physical characteristics

Construction: Modular two-part, both stainless steel boxes with handle

Dimensions: 2 parts of 240mm x 120mm x 85mm

Weight: 2 x 2.5kg

Protection: to IP68, fully potted

Hydraulic Actuator

Refer to separate data sheet describing this item

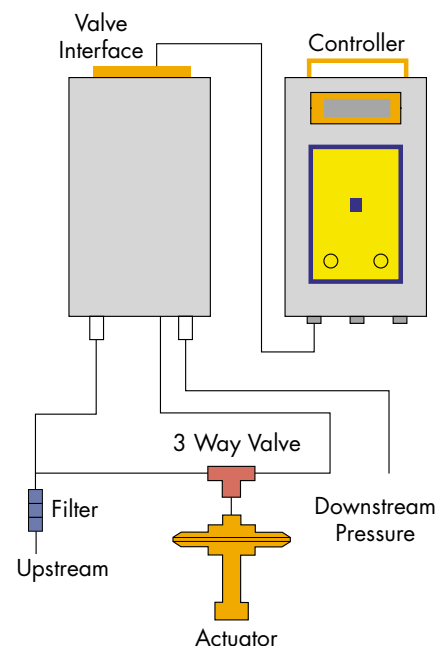

Schematic of installation

Palmer Environmental is the world leader in the field of leakage control equipment.

Our product range includes:

- Data loggers for flow, pressure and other parameters
- Leak noise logging, correlation and acoustic systems
- Permalog® – telemetry-based installed leak detection system
- Pressure management systems for controlling PRV operation
- GSM, radio telemetry, land-line and other communications systems
- Integrated network management software

For details of our full product range, or for information on a specific product, please contact Palmer Environmental or your Palmer representative.

Ty Coch House, Llantarnam Park Way, Cwmbran, NP44 3AW, United Kingdom
 Tel: +44 (0)1633 489479 Fax: +44 (0)1633 877857
 Email: info@palmer.co.uk Website: www.palmer.co.uk

